

SUB-SECTION ND CENTRAL BATTERY WIRING

CENTRAL BATTERY WIRING

PAGE ND2

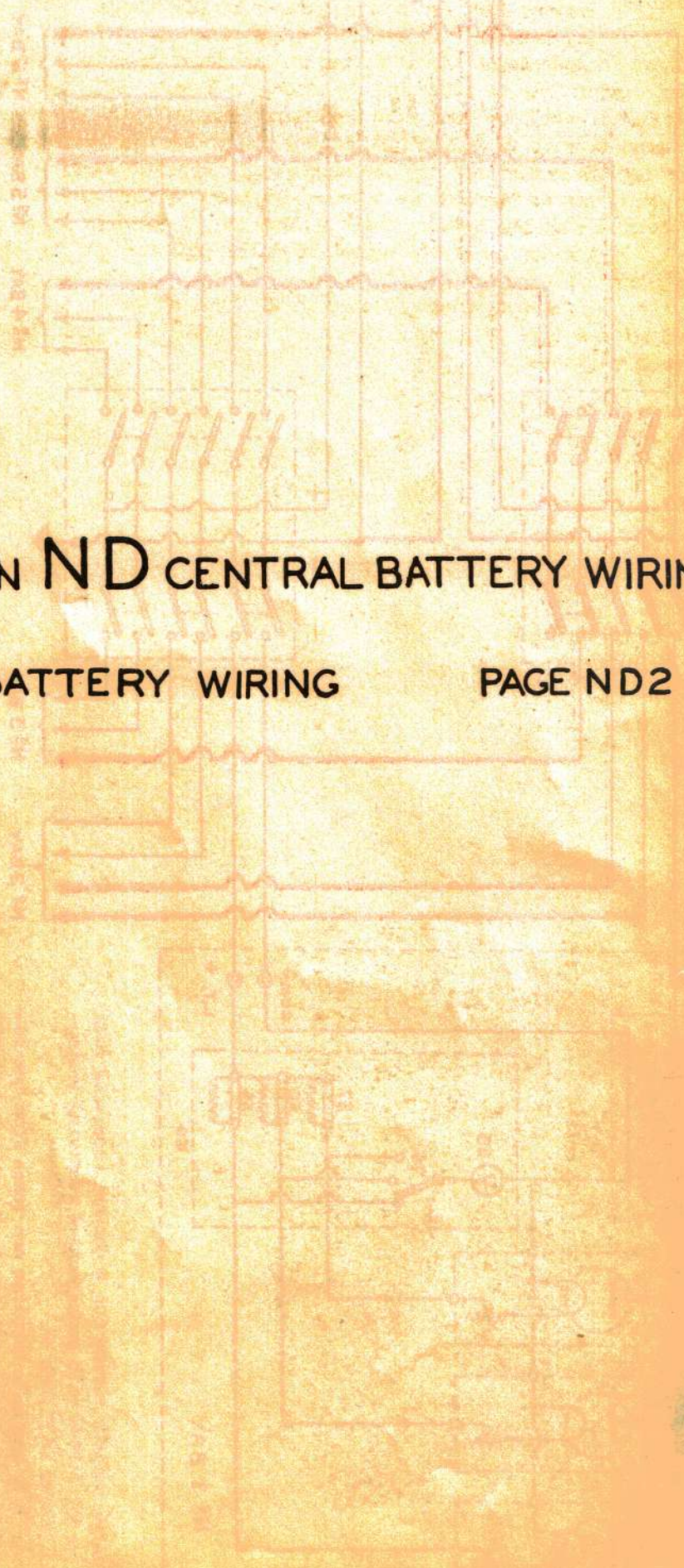

CENTRAL BATTERY WIRING

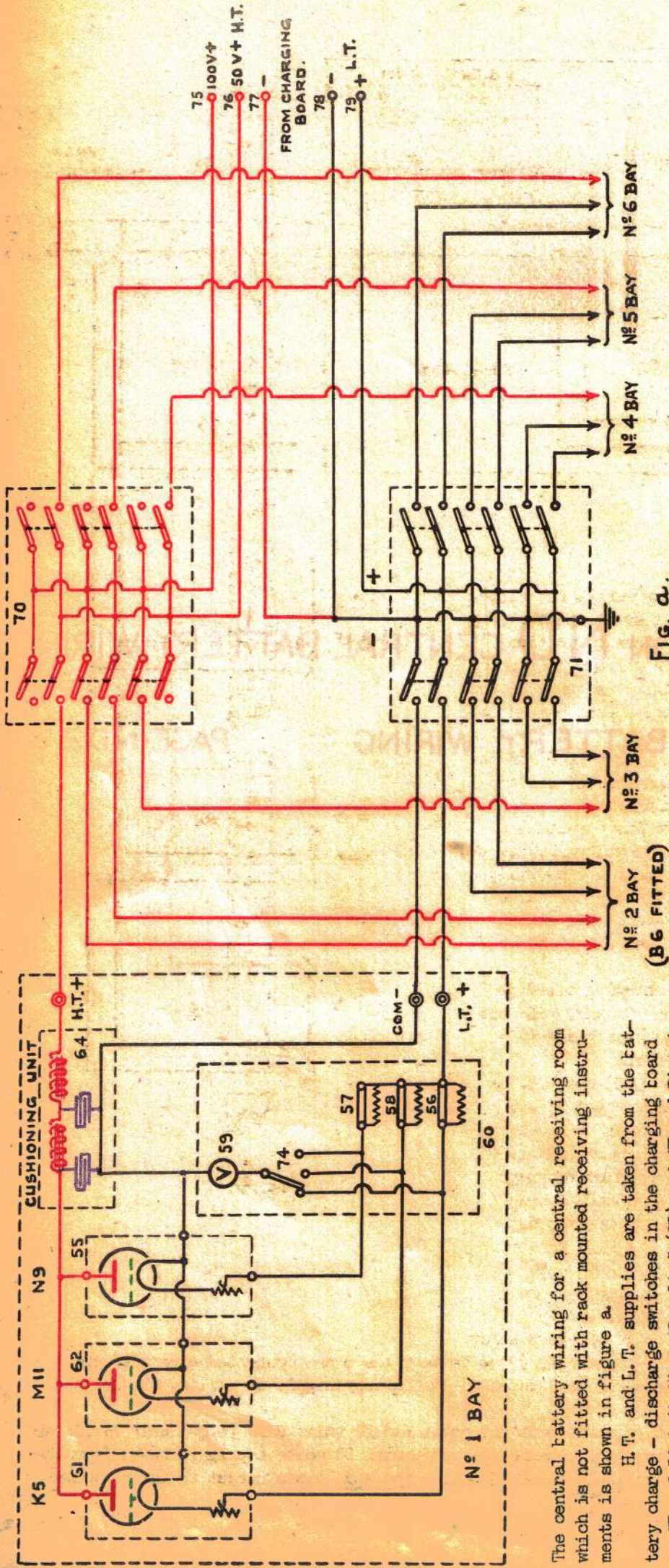

FIG. a.

The central battery wiring for a central receiving room which is not fitted with rack mounted receiving instruments is shown in figure a.

H. T. and L. T. supplies are taken from the battery charge - discharge switches in the charging board to "Board Distributing 48 volts" (70) and "Board Distributing 6 volts" (71) in the central receiving room.

Three H. T. supply leads, 100 volt positive, 50 volts positive and H. T. negative, and two L. T. supply leads, are run between the charging board and the C. R. R. The two negative leads are made common and connected to the L. T. negative terminal on "Board Distributing 6 volts" (71). From the "Board Distributing 48 volts" (70) the 50 volts and/or 100 volts positive supply is distributed to the various bays, each bay being supplied through a separate D.P. switch on the board. The common negative lead is earthed at the "Board Distributing 6 volts" (71) and from this board two L. T. leads are run to each bay through separate D.P. switches. At each bay a cushioning unit (64) is fitted in the H. T. positive lead to prevent A/F voltage variations in the output of the receiver in the bay being applied to the receivers in the other bays by resistance coupling due to the common battery. The cushioning unit (64) consists of two A/F chokes connected in the H. T. positive lead and two 2 mfd. condensers connected between H. T. positive and common negative.

The L. T. positive lead is connected to a "Board Distributing 6 volt, 6 way" (60). On this board (60) semi-adjustable resistances are fitted, one for each receiving model in the bay. These resistances (56)(57)(58) were originally required for adjusting the L. T. input voltage at the terminals of the various receiving models. Since the introduction of dull emitter valves these resistances are generally short-circuited. A voltmeter (59) and selector switch (74) are fitted on this board (60) to enable the L. T. input voltage to each receiving model to be read.

CENTRAL BATTERY WIRING (RACK MOUNTED INSTRUMENTS)

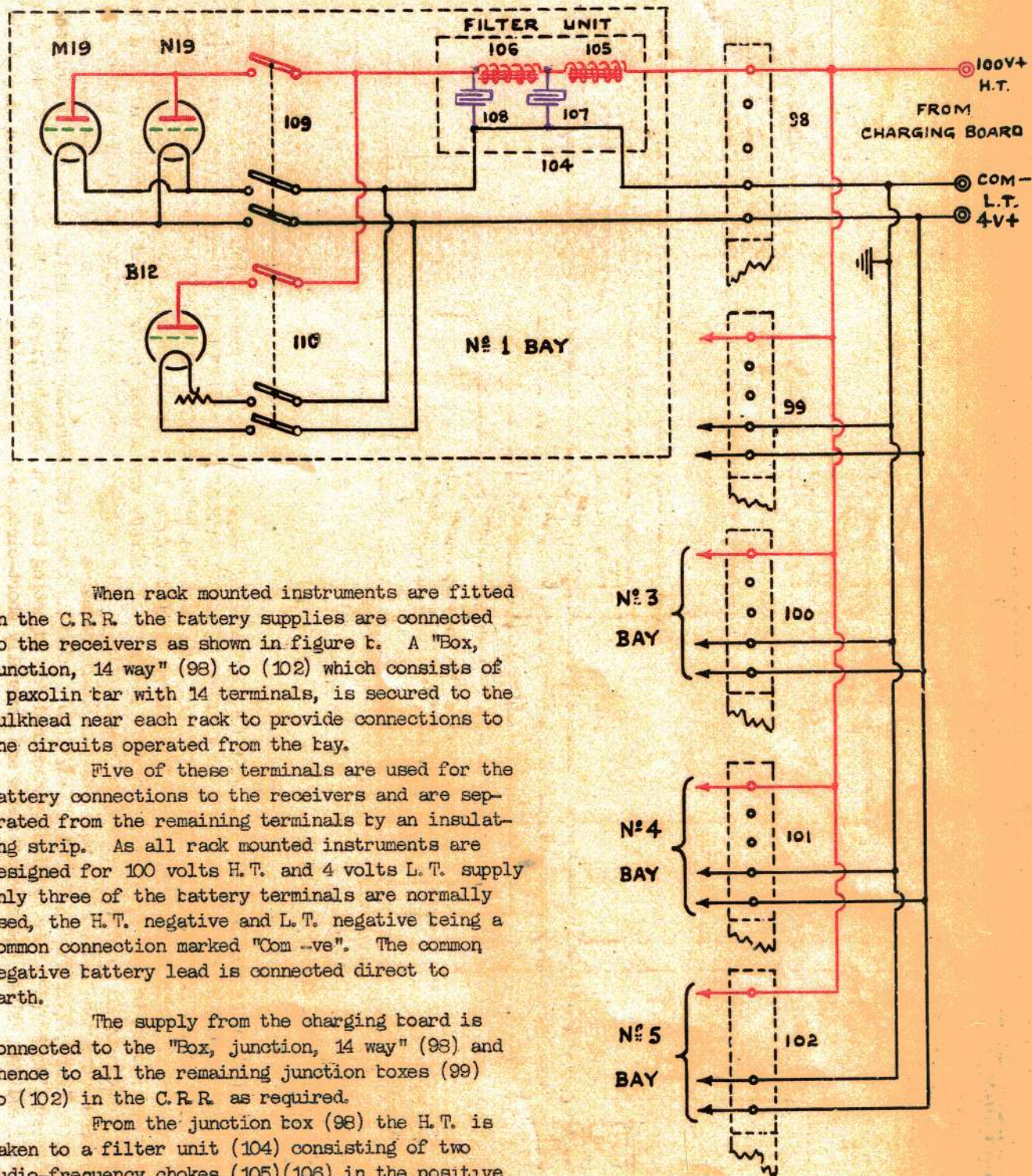

FIG. 6.

When rack mounted instruments are fitted in the C.R.R. the battery supplies are connected to the receivers as shown in figure 6. A "Box, junction, 14 way" (98) to (102) which consists of a paxolin bar with 14 terminals, is secured to the bulkhead near each rack to provide connections to the circuits operated from the bay.

Five of these terminals are used for the battery connections to the receivers and are separated from the remaining terminals by an insulating strip. As all rack mounted instruments are designed for 100 volts H.T. and 4 volts L.T. supply only three of the battery terminals are normally used, the H.T. negative and L.T. negative being a common connection marked "Com -ve". The common negative battery lead is connected direct to earth.

The supply from the charging board is connected to the "Box, junction, 14 way" (98) and thence to all the remaining junction boxes (99) to (102) in the C.R.R. as required.

From the junction box (98) the H.T. is taken to a filter unit (104) consisting of two audio-frequency chokes (105)(106) in the positive lead with two 8 mfd by-pass condensers (107)(108) connected between H.T. positive and common negative. The filter unit (104) is fitted to ensure that A/F voltages do not get to other bays due to resistance coupling through the H.T. battery. The H.T. positive from the filter unit, L.T. positive and the common negative supplies are connected to a 3 pole "H.T. and L.T. supply switch" (109) fitted on the side of the rack below the operator's bench. From this switch (109) the battery leads are connected direct to the receiver which can thus be completely isolated from the battery supply by pulling the switch to "OFF".

When a receiver which requires both 100 volts and 50 volts H.T. (e.g. Tuner Amplifier B6) is fitted in a rack as a temporary measure the additional 50 volts supply is taken from the battery to one of the battery terminals in the junction box and thence direct to the 50 volts H.T. terminal on the receiver.